



TRANSPORTATION FOR ELECTRICAL VEHICLES PLAYS A MAJOR ROLE IN THE AUTOMOBILE INDUSTRY

**Dr.SP.Arunkumar^{1*}, Mr.M. Arther Clive², Dr.R.Anand³, Dr.P.Maniarasan⁴,
Dr.M.Balakrishnan⁵**

^{1*} Associate Professor, Department of Mechatronics Engineering, Nehru Institute of Engineering and Technology, Coimbatore, Mail ID: arungreesma@gmail.com.

² Assistant Professor, Department of Mechanical Engineering, Akshaya college of engineering and technology, kinathukadavu, Coimbatore, Mail ID: martherclive@gmail.com.

³ Associate professor, Department of Electrical and Electronic Engineering, Nehru Institute of Engineering and Technology, Coimbatore, India. Mail ID: anandrb.pk@gmail.com.

⁴ Professor, Department of Aeronautical Engineering, Nehru Institute of Engineering and Technology, Coimbatore, India. maniarasan@gmail.com.

⁵ Assistant Professor, Mechatronics Engineering, Nehru Institute of Engineering and Technology, Coimbatore, India. Mail ID: balakrishnn0002@gmail.com

***Corresponding author: Dr.SP.Arunkumar**

* Associate Professor, Department of Mechatronics Engineering, Nehru Institute of Engineering and Technology, Coimbatore, Mail ID: arungreesma@gmail.com

:	<p style="text-align: center;">Abstract</p> <p>In recent years, people have grown to appreciate using electric vehicles as transportation. According to the circumstances, electric vehicle drives have a number of advantages over ICE cars, mainly in terms of reduced local pollutants, increased energy efficiency, and reduced reliance on oil. However, a number of obstacles, such as limitations in battery technology, high purchasing costs, and therefore a lack of recharging infrastructure, are preventing the quick adoption of electric vehicles. To fully replace ICE cars, EVs must first overcome a few significant challenges. The primary focus of this essay is on some crucial details regarding electric vehicles, such as their many types, electrical equipment, and batteries. This paper's goal is to give information on the existing and future state of electric vehicle technology.</p> <p>Key Words: Types Electric Vehicle (EVs), Batteries & specifications, Motor used in EVs</p>
---	---

CC License
CC-BY-NC-SA 4.0

1. Introduction

Electric vehicles (EVs) and battery technology are constantly improving, but there are still several downsides, including high cost, a small driving range, performance difficulties, a lengthy charge time, and a decreasing number of charging stations. When there are more electric vehicles on the road, we may anticipate better air because they have no tailpipe emissions 3. Less sickness in the globe implies cleaner air equals less strain on hospitals, public health systems, and other institutions. We can conserve the ozone layer and lessen our carbon footprint by reducing greenhouse gas emissions. EVs are nothing if not an honest beginning, and if we can't halt heating, we will undoubtedly slow down the process. Neither oil nor gas must be varied or purchased. You only need to link reception to refill while at work, on the road, or at reception 5.

The facility used to charge your electric vehicle's batteries is becoming increasingly produced from renewable sources, which is an additional benefit of EV charging. Domestically produced non-renewable energy is used to charge your electric autos. Your commute may pay for a solar battery if you install one at home or work. Driving an electric car indicates that you are thinking long term.

There are several reasons why electric vehicles are becoming more and more popular nowadays. As EVs become more prevalent in transportation, reducing carbon emissions is crucial. EVs are frequently viewed as a combination of different subsystems working together to create an EV. There are certain cars that use both the Engine and the electrical motors simultaneously as EVs are frequently only powered by stored electric energy. However, some EVs can also produce this energy from an ICE 18. The broad category of EVs is covered in order to explain current technology scenario. The most significant concern may potentially be needing to replace your battery, however most models come with a solid guarantee nowadays. 8. In a moderate environment, batteries can last up to 15 years, which, in any case, is a very excellent bargain. This also includes an explanation of the many types of batteries used in electric cars 10. BEVs vary from traditional cars in that they have motors instead of engines as their primary power source. As a result, the study describes the various motors utilised in BEVs.

2. Types of Electric Vehicles (EVs)

There are four main types of EV-

- o Hybrid Electric Vehicle (HEV)
- o Plug-in-hybrid Electrical Vehicle (PHEV)
- o Fuel cell electric vehicle (FCEV)
- o Battery Electric Vehicle (BEV)

Hybrid Electric Vehicle (HEV)

A hybrid electric vehicle (HEV) is a vehicle featuring an electric power system in addition to a traditional internal combustion engine (ICE). greater performance or greater fuel efficiency than a regular car are the goals of the electrical Powertrain's presence. In times of low energy demand, HEV employs an electrical system. Low speed applications can benefit from it. It also consumes less gasoline because of a decrease in fuel usage. HEVs may renew energy by braking since ICE can stir up batteries. Electric propulsion is used in HEVs to improve performance and ICE serves as the primary motor. Figure 1 depicts the flow of energy in a HEV. The starter serves as a generator to create the power that is stored in batteries. Motor and ICE both operate the motor when passing since the speed requirement is greater 2. Regenerative braking charges the battery when the motor is operating as a generator during braking. The vehicle's halt stops the facility's flow.

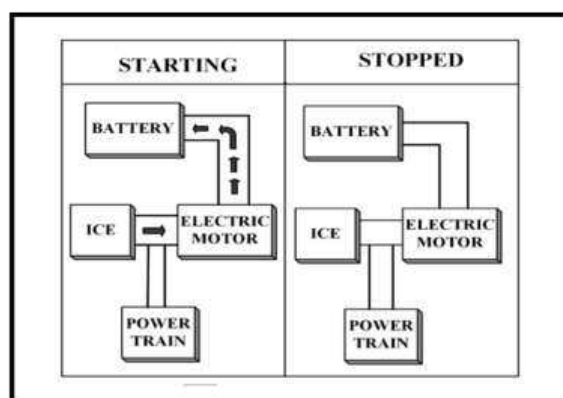

FIG -1: POWER TRAIN IN HEV 8

Plug-in-hybrid Electrical Vehicle (PHEV)

Both ICE and electrical machinery are found in PHEVs. The sole distinction between it and a HEV is that a PHEV has electric propulsion as its primary means of propulsion³. They need larger capacity batteries than HEVs do for this reason. When the battery is low on charge or depleted, the PHEV uses an ICE to give power to the electric motor and recharge the battery pack. A PHEV may be charged using an outside source. The

capability of regenerative braking is another feature of PHEV. The PHEV has even greater promise than traditional hybrids since it may be possible to operate the internal combustion engine of the PHEV closer to its optimum efficiency.

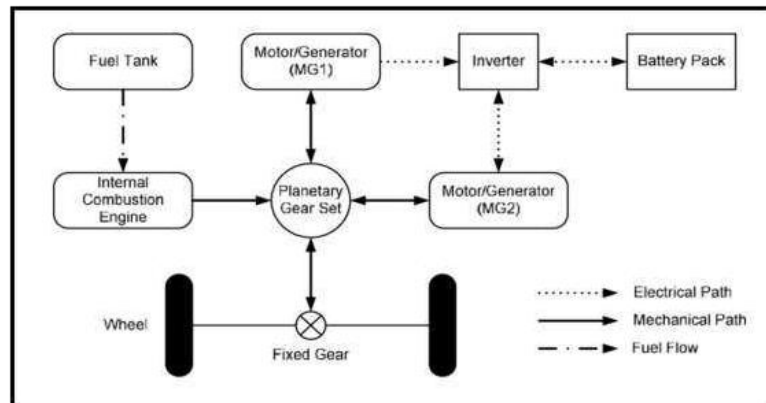

FIG - 2: PHEV 21

Fuel cell electric vehicle (FCEV)

Fuel cells power the electric motor, which is why the vehicle's name, FCEV, refers to fuel cells. The fuel cell experiences chemical reactions. Since hydrogen is frequently chosen for the processes, they are sometimes referred to as "Hydrogen Fuel Cell EVs." FCV has high pressure tanks where hydrogen is processed. This process also makes use of oxygen, which is obtained from the environment. Super capacitors and batteries are used to store the energy produced by this process. Only a byproduct, water, is created. Consequently, this sort of vehicle's benefits include the fact that it emits no carbon into the atmosphere and that it can be refilled in the same amount of time as a regular vehicle. However, there are safety concerns over the possibility of combustible hydrogen leaking from the tank. Figure 3 displays information on FCEV.

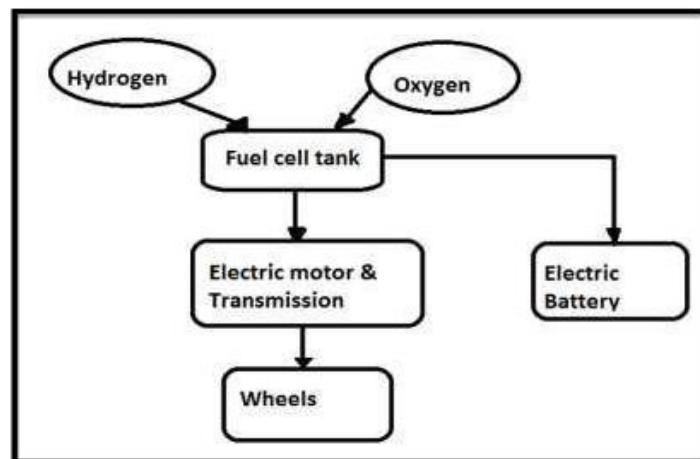

FIG - 3: FUEL CELL ELECTRIC VEHICLE.

Battery Electric Vehicle (BEV)

BEVs are cars that are exclusively powered by batteries. Only battery energy is used to power the electric motor. Thus, it is evident that a vehicle's range directly depends on its battery capacity. 9. The vehicle's top speed is influenced by the battery's kind and age, the road's condition, the vehicle's design, and other factors. Compared to a traditional ICE car, battery packs require a long time to charge when the batteries are completely drained. 8. The charging time is determined by the charger's operational power level and setup. The BEV is easy to make and use. They don't make any noise at all. These are the ideal cars to drive in cities. Basics of BEV are shown in figure 4 below.

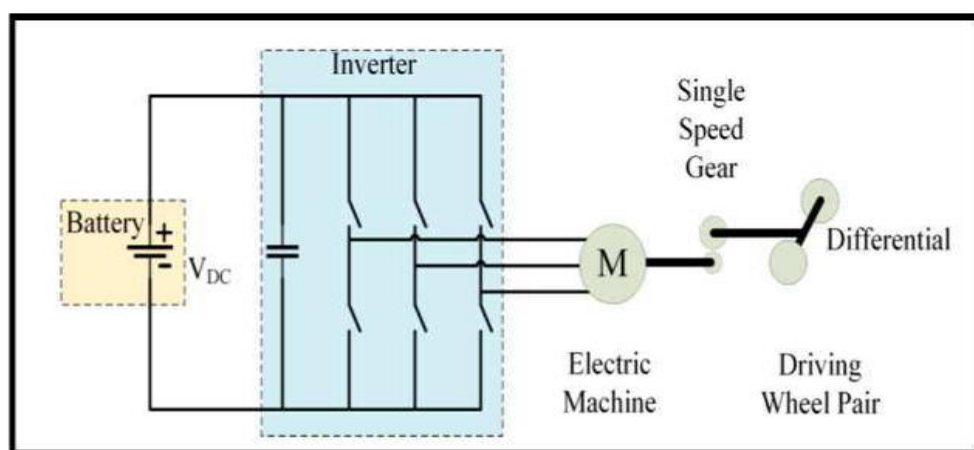

FIG - 4: BEV 8

Comparison analysis

TABLE -1: COMPARISON WITH ELECTRIC VEHICLES 138

Vehicle Type	Electric Vehicle (EV)	Fuel Cell (FCEV)	Plug-in-Hybrid (PHEV)	Hybrid (HEV)
ENERGY POTENTIAL	Electric Only (Battery)	Fuel only	Main: Electric Sub: Gasoline	Main: Gasoline Sub: Electric
PROPULSION MECHANISM	Motor	Motor	Combination of Motor + engine	Combination of Motor + engine
CO ₂ EMISSION	None	None	Yes	Yes
REFUELING	Charging Stations		Gas Stations, Chargers	Gas Stations
DISTANCE	Short	Short	Long	Long

3. BATTERY

The battery, which transforms energy from chemicals into electrical energy and supplies that energy to electrical vehicles, is a significant energy source. Although there are many different types of batteries and each has its own specifications, certain battery specifications haven't been successful in achieving desired results, thus research into battery performance is ongoing. choosing a battery for an electric car is Another essential element for obtaining the highest energy output, a longer lifespan, more efficiency, safety while usage, a battery that is relatively lighter than all others for the same rating, and many other benefits is an electrical vehicle. The most crucial component of a battery is specific energy, as high specific energy results in the greatest possible range for an electrical vehicle. Therefore, while making a decision, Specific energy will be mostly considered.

Types of Batteries:

There are various types of battery technologies used in electric vehicle as follows:

- Lead-acid Battery
- Nickel Cadmium (NiCd) battery
- NiMH (Nickel-Metal Hydride) battery
- Lithium-ion (Li-ion) Battery

3.1.1 Lead-acid

Lead-acid battery charging and discharging is caused by an electrolyte and electrode interaction. 10. In the past, lead-acid batteries were most frequently used in electric vehicles due to their inexpensive cost, however they should never be drained below 50% of their entire capacity since this will shorten their life cycle 8. Similar to how these batteries must be charged with extra caution since they are never fully charged 11. The solution is being depleted and gases are being produced as a result of excessive charging. Lead-acid Compared to other battery kinds, acid devices are more effective, having an optimum energy of 30–40 Wh/kg. During the charging and discharging processes of the battery, emissions of hydrogen, oxygen, and

sulphur occur. The charging and discharging processes are safe if the battery is adequately vented. In comparison to rechargeable batteries, the lead-acid battery's charge retention was good⁴.

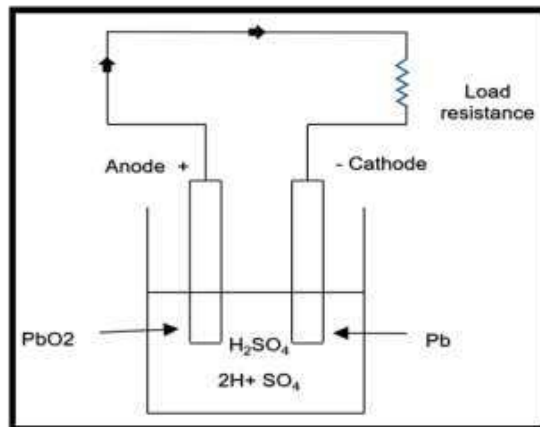

FIG -5: LEAD-ACID BATTERY

3.1.1 Nickel Cadmium (NiCd) battery

In applications where factors like battery life cycle, battery cost, and discharge rate are taken into account, nickel cadmium (NiCd) batteries are employed. NiCd batteries charge in a relatively short amount of time, give more load current, and have the lowest total cost per cycle, but they still need frequent maintenance. NiCd batteries have a high operating efficiency even in difficult working conditions, however they include hazardous metals that have an adverse environmental impact^{8,22}. The capacity of the battery will decline by approximately ten percent in the initial day after charging, then it will fall by about 10% over the course of the following 30 days, and the battery discharge themselves rate will rise as the temperature rises⁴. People will choose new breakthroughs in technology due to the existence of harmful metals and the need for better energy density.

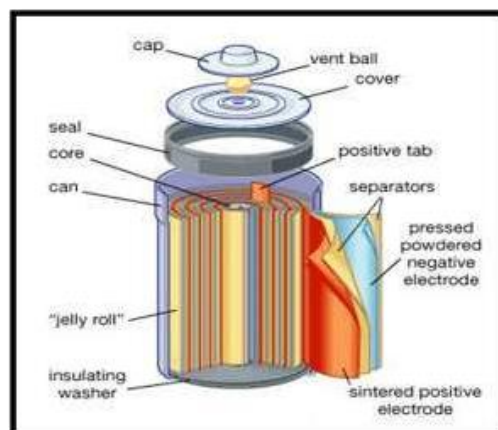

FIG -6: NICKEL CADMIUM (NICD) BATTERY 22

NiMH (Nickel-Metal Hydride) battery

Nickel-metal hydride batteries now have several extra advantages over NiCd batteries thanks to certain research and development. NiMH (Nickel-Metal Hydride) batteries give off more energy (>30–40%) than NiCd batteries, but they are less efficient at both charging and discharging than NiCd batteries¹¹. If batteries are used properly, however, they may run safely at high voltages and across a broad temperature range and have a longer lifespan¹¹. They also give the choice of recycling. On the other hand, operating under severe load, a rapid self-discharging rate, and performance declines in cold environments will all shorten the life cycle. NiMH batteries are pricey and need a lot of upkeep. Comparing NiMH with NiCd batteries, NiMH is more appropriate for use in electric vehicles (EVs) since NiCd includes poisonous metal, which is dangerous and not ecologically friendly⁴.

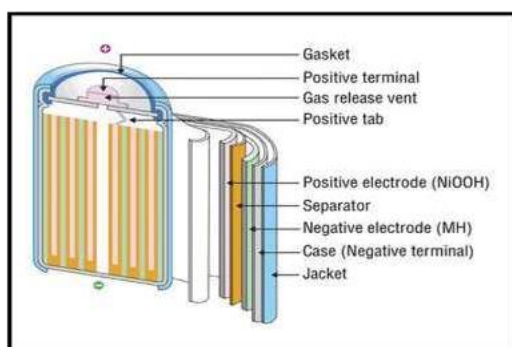

FIG -7: NIMH BATTERY 22

Lithium-ion Battery

Rechargeable batteries in general, lithium-ion batteries are frequently utilised in portable electronics and electric vehicles. Because of its key benefits, including the lightest battery in weight, highest energy density, and longest life of all batteries, these types of batteries are more advanced technologically than other batteries and suited for electric cars. Because of this, it is the sole battery utilised in current electrical cars. 26. Because it has an extremely low self-discharge rate compared to all other batteries, this battery is the best choice for electrical cars. Lithium-ion batteries need to be charged with extra caution since they are extremely susceptible to excessive heat, overcharging, and severe battery discharge 7. The battery needs a protective circuit in order to function safely. When using a Li-ion battery in an electric car, the user is required to employ a "Battery management system" to balance the cells. 4

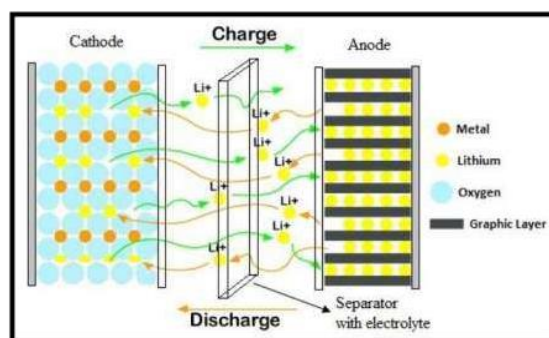

FIG -8: LITHIUM-ION BATTERY WITH CHARGING AND DISCHARGING 12

Comparison of Batteries:

The following comparison is based on the particular specification of batteries that can represent itself and will give the required information for the selection of battery technology for the Electrical vehicle system.

TABLE -2: COMPARISON WITH BATTERY TYPES

Particulars	Specification of Batteries			
	Lead acid	Nicd	Ni-MH	Li-ion
SPECIFIC ENERGY (WH/KG)	20-40	40-65	45-80	90-190
SPECIFIC POWER (W/KG)	75-415	100-175	200-1500	500-2000
NOMINAL VOLTAGE(V)	2	1.25	1.25	3.6
RATED CAPACITY (MAH)	20000	28000	23000	5300
SELF-DISCHARGE/MONTH (%)	5	20	30	10
CHARGING TIME (H)	8-16	1	2-4	2-4
Life cycle	200-2000	1500	300-500	500-1000
PEAK DRAIN (C)	5	20	5	2
ENERGY EFFICIENCY (%)	70	60-90	75	80
THERMAL STABILITY	Least stable	Least stable	Least stable	Most stable
SELF-DISCHARGE	Low	Moderate	High	Very low
OVERCHARGE TOLERANCE	Moderate	Low	High	Very low
MAINTENANCE REQUIREMENT	3 to 6 months	30 to 60 days	60 to 90 days	Not req.
INTERNAL RESISTANCE	100 to 200	200 to 300	<100	150 to 250
(INCLUDES PERIPHERAL				

CIRCUITS) IN MΩ	6v pack	6v pack	12v pack	7.2v pack
OPERATING TEMPERATURE (DISCHARGE ONLY)	-20 to 60°C	-40 to 60°C	-20 to 60°C	-20 to 60°C
COST (\$/KWH)	8.5	7.5	18.5	24

According to the analysis above, lithium-ion batteries are the most appropriate battery technology to employ in electrical vehicles. The lithium-ion battery is the only battery that can meet the demands of electrical cars since it is the lightest battery in weight, has the highest energy density, and has a longer lifespan than all other batteries.

4. MOTOR

Typically, four preferred motor types for EV (Electrical Vehicle) propulsion are addressed. Research is being done on electrical motor drives like brushing DC motor drives, a permanent magnet brushless DC motor, the induction motor, and permanent magnet synchronised motor (PMSM) in order to find more suitable electric motor drives for driving electric vehicles. The requirements of EVs on electric motor drives include efficiency, a weight, price, chilling, maximum speed, and fault-tolerance.

Brushed DC Motor

According to Fleming's left hand rule, a brushed DC motor's rotor functions as a permanent magnet and the stator as a rotating magnetic field when a conductor that carries current is placed in a magnetic field, which causes the conductor to experience a mechanical force and produce a torque that turns the DC motor 19. Due to the existence of the mechanical commutator and brushes, brushed DC Motor drives have a bulkier design, lower efficiency, greater maintenance requirements, and are less dependable. Brushed DC motors used in this construction are more costly and heavier (16). In addition, friction between the commutator and the brushes maintains the maximum motor speed restrictions

BLDC Motor

Use brushless DC motors to make the operation of EVs (Electrical Vehicles) more dependable, efficient, and quiet. With the same power, they are lighter than brushed DC motors. We never utilise the operational demand for extended life & dependability since the brushes of DC motors wear out. Because it lacks a commutator and brushes, BLDC is also known as a brush less motor. It is comparable to a DC motor and has a PM (Permanent Magnet). 19Electrically powered brushless DCMOTORS with maintenance-free BLDC motors that have strong starting torque and high efficiency levels of 95% to 98% are used for commutation. Its high starting torque results from the lack of brushes, which means there won't be any friction during commutation. Due to its traction, brushless DC motors are the most popular choice for electric vehicle applications.

Working:

The rotor of the BLDC motor is a permanent magnet, the stator has a Coil arrangement showing out-runner type BLDC motor in following figure. To energize the coil the DC supply is applied due to which coil act as an electromagnet.

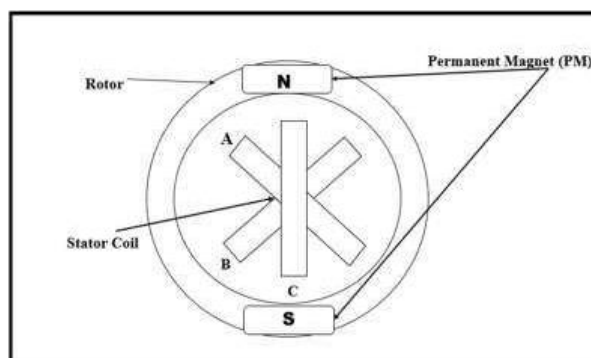

Fig -9: Out-runner type BLDC Motor

The electromagnet and permanent magnet interact simply by force to power the BLDC system. The rotor and stator's alternate poles are drawn to one another when coil A is energised in this situation because when the

rotor gets close to coil A, coil B energises, and vice versa. The whole process is repeated while the rotor rotates.

In BLDC, a sensor identifies the location of the rotor, and based on this knowledge, the controller decides which coils to energise in order to obtain continuous rotation from the rotor and randomly energise the stator coils. The configuration of the electronic sensor is depicted in FIGURE NO. A Hall Effect sensor is often used for the application.

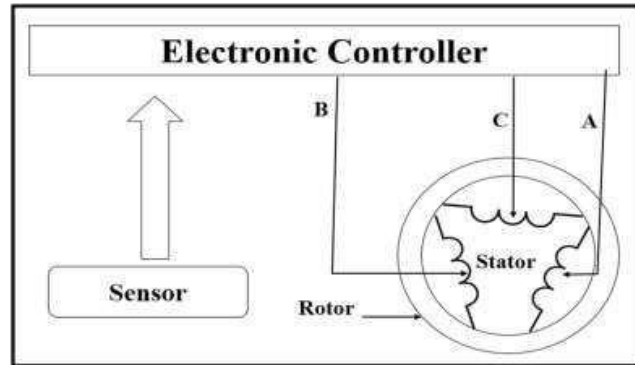

FIG -10: ELECTRONIC CONTROLLER ARRANGEMENT WITH SENSOR FOR BLDC MOTOR

There are two types of BLDC motor:

Out-runners Type BLDC Motors

This sort of motor, which has an outside rotor and an inside stator, is also known as a HUB motor since the wheel is directly attached to the exterior rotor. An external gearing system is not necessary for this kind of motor. Due to the lack of a gear system and the need for space monitoring, this motor reduces the total size of the vehicle and is popular among electric manufacturers of bicycles and two-wheelers.

In-runner Type BLDC Motor

This motor's rotor is inside and stator is outside, so it requires an extended transition system to transfer the power of the wheel. As a result, the outer runner configuration is less bulky than the internal configuration. Many two and three wheel vehicles, including another 450, use this motor. It operates on the same principles as an out runner motor, except that the cases magnets are inside and the rotor is inside.

Induction motor

What is RMF (rotating magnetic field)? When a wire is carrying current, it creates a magnetic field around it. When the three cables are connected to each other at a distance of 120 degrees and are each given three phases, all three wires will produce a magnetic field around the variation in AC current that results in RMF. Synchronous speed 14 refers to the rate of rotation of these magnetic fields.

Permanent Magnet Synchronous Motor (PMSM)

This motor has properties with BLDC motors, which have permanent magnets on every rotor and have great power densities and efficiency. For high power rating, PSSM (Permanent Magnet Synchronous Motor) are available. For high-performance applications, such as cars and buses, this is the ideal option. 18

Working:

The rotor generates a constant magnetic field, while the stator generates a rotating magnetic field. The interaction between the rotor and the revolving magnetic field is what gives the speed characteristics they have. This process' rotating magnetic field is supplied by the field coil stator stimulated by three-phase AC and revolves at synchronous speed²⁰. The rotor is a permanent magnet that generates a constant magnetic field. When there is a rotating magnetic field, the opposite poles of the rotating magnetic field and the rotor will attract one another and become mechanically locked, which will cause the rotor to rotate at the same speed as the rotating magnetic field and will cause the rotor to move, which will cause the vehicle to move.

Synchronous speed derived as:

$$NS = (120F/P)$$

- NS= speed of the rotor in RPM.
- F=Frequency.

Available online at: <https://jazindia.com>

➤ P= numbers of poles.

So, if we can control the frequency of electricity supply then the speed of the synchronous speed motor accurately controlled.

Comparison of Electrical Motors in electrical vehicle:

TABLE -3: ELECTRICAL MOTORS 820

Feature	Brush DC Motor	Brushless DC Motor	Induction Motor	Permanent Magnet Synchronous Motor
SPEED TORQUE CHARACTERISTICS	Moderate loss in torque at higher speeds because of losses in brushes	Flat-operation at all speeds with rated load	Non linear	Speed is constant irrespective of loadsability to control power
COMMUTATION METHOD	Mechanical contact between brushes & commutator	Using solid switched	Special starting circuit isrequired.	Using solid switched
DETECTING METHOD OF ROTORS POSITION	Automatically detected by brushes & commutator	Hall sensors, opticaencoder.	NA	NA.
REQUIRED CONTROLLER	No controller is required for a fixed speed & it is required for variable speed	A controller is always required to control the commutation sequence	Controller isn't required for a fixed speed & it is required for variable speed	Controller isn't required for a fixed speed & it is required for variable speed
DIRECTION REVERSAL	Reversing the terminalvoltage	Reversing the switching sequence	By reversing any two phase of motor input	By reversing any two phase of motor input
MECHANICAL STRUCTURE	Field magnet on the rotor & stator are made up of permanent magnet or an electromagnet	Rotor is permanent magnet & stator has a Coil arrangement	Stator has winding & AC lines are connected to the stator	Stator is Field Coil & Rotor is a PermanentMagnet
DIRECTION REVERSAL	Reversing the terminalvoltage	Reversing the switching sequence	By reversing any two phase of motor input	By reversing any two phase of motor input
ELECTRICAL NOISE	High because of brushes	Less	Less	Less
MAINTENANCE	Periodic maintenance because of brushes	No or Less maintenance	Less maintenance	No or Less maintenance
EFFICIENCY	Moderate, losses due to brushes	High, brushes	No & stator, high efficiency motors are also available (higher cost)	High, No brushes
SYSTEM COST	low	High, because external controller requirement	Low	High, because external controller requirement or PMare expensive.

5. CONCLUSION

This study aims to focus on the essential elements of EV. EVs fall under the BEV, HEV, and PHEV categories. As the transportation of the future with the greatest potential to save the globe from impending tragedies brought on by global warming, BEVs have gained widespread acceptance. Batteries are the primary energy source for modern EVs. Lead-acid and NiMH battery types are no longer in use, and battery technology has undergone major modifications. Although Li-ion batteries are now in use, they often aren't powerful enough to generate the amount of energy needed to calm consumers suffering from "range anxiety." Therefore, developing batteries with greater capacity and better power densities must be the main emphasis of research in this field. For EV usage, many motor types may be used. Induction motors, permanent magnet synchronous motors, and synchronous reluctance motors are among the well-known

types. Due to their dependency on permanent magnets made of rare-earth materials, induction motors are widely used now and might rule in the future.

REFERENCES

1. N. Penina, Y. V. Turygin and V. Racek, "Comparative analysis of different types of hybrid electric vehicles," 13th Mechatronika 2010, Trencianske Teplice, 2010, pp. 102-104.
2. Ghosh, Aritra. (2020). Possibilities and Challenges for the Inclusion of the Electric Vehicle (EV) to Reduce the Carbon Footprint in the Transport Sector: A Review. *Energies*. 13. 2602. 10.3390/en13102602.
3. H. Zakaria, M. Hamid, E. M. Abdellatif and A. Imane, "Recent Advancements and Developments for Electric Vehicle Technology," 2019 International Conference of Computer Science and Renewable Energies (ICCSRE), Agadir, Morocco, 2019, pp. 1-6, doi: 10.1109/ICCSRE.2019.8807726.
4. V. V. Shimin, V. A. Shah and M. M. Lokhande, "Electric vehicle batteries: A selection based on PROMETHEE method," 2016 IEEE 7th Power India International Conference (PIICON), Bikaner, 2016, pp. 1-6, doi: 10.1109/POWERI.2016.8077224.
5. G. Suciú and A. Pasat, "Challenges and opportunities for batteries of electric vehicles," 2017 10th International Symposium on Advanced Topics in Electrical Engineering (ATEE), Bucharest, 2017, pp. 113-117, doi: 10.1109/ATEE.2017.7905058.
6. X. Chen, W. Shen, T. T. Vo, Z. Cao and A. Kapoor, "An overview of lithium-ion batteries for electric vehicles," 2012 10th International Power & Energy Conference (IPEC), Ho Chi Minh City, 2012, pp. 230-235, doi: 10.1109/ASSCC.2012.6523269.
7. E.M.G. Rodrigues, R. Godina, G.J. Osório, J.M. Lujano-Rojas, J.C.O. Matias, J.P.S. Catalão University of Beira Interior, Covilhã, Portugal, and INESC-ID, IST, University of Lisbon, Lisbon, Portugal" Comparison of different Battery Types for Electric Vehicles.
8. Un-Noor, F.; Padmanaban, S.; Mihet-Popa, L.; Mollah, M.N.; Hossain, E. A Comprehensive Study of Key Electric Vehicle (EV) Components, Technologies, Challenges, Impacts, and Future Direction of Development. *Energies* 2017, 10, 1217.
9. Flah, Aymen & Lassaad, Sbita & Mahmoudi, Chokri. (2014). Overview of Electric Vehicle Concept and Power Management Strategies. 2014 International Conference on Electrical Sciences and Technologies in Maghreb, CISTEM 2014. 10.1109/CISTEM.2014.7077026.
10. K. W. E. Cheng, "Recent development on electric vehicles," 2009 3rd International Conference on Power Electronics Systems and Applications (PESA), Hong Kong, 2009, pp. 1-5.
11. E.M.G. Rodrigues, R. Godina, G.J. Osório, J.M. Lujano-Rojas, J.C.O. Matias, J.P.S. Catalão University of Beira Interior, Covilhã, Portugal, and INESC-ID, IST, University of Lisbon, Lisbon, Portugal "Comparison of Battery Models for Energy Storage Applications on Insular Grids"
12. M. A. Hannan¹, Senior Member, IEEE, M. M. Hoque², Student Member, IEEE, Aini Hussain³, Yushaizad Yusof³, P. J. Kerl,³ "State-of-the-Art and Energy Management System of Lithium-Ion Batteries in Electric Vehicle Applications: Issues and Recommendations."
13. Porselv, T., Jayanty Ashok and Anjan Kumar. "Selection of Power Rating of an Electric Motor for Electric Vehicles."(2017).
14. X. D. Xue, K. W. E. Cheng and N. C. Cheung, "Selection of eLECTRIC mOTOR dRIVES for electric vehicles," 2008 Australasian Universities Power Engineering Conference, Sydney, NSW, 2008, pp. 1-6.
15. Nadolski, Roman & Ludwinek, Krzysztof & Staszak, Jan & Jaśkiewicz, Marek. (2012). Utilization of BLDC motor in electrical vehicles. *Przegląd Elektrotechniczny*. 88.
16. Racewicz, Szymon & Kazimierczuk, Paweł & Kolator, Bronisław Andrzej & Olszewski, Andrzej. (2018). Use of 3 kW BLDC motor for light two-wheeled electric vehicle construction. *IOP Conference Series: Materials Science and Engineering*. 421. 042067. 10.1088/1757-899X/421/4/042067.
17. M. Yildirim, M. Polat and H. Kürüm, "A survey on comparison of electric motor types and drives used for electric vehicles," 2014 16th International Power Electronics and Motion Control Conference and Exposition, Antalya, 2014, pp. 218-223, doi: 10.1109/EPEPEMC.2014.6980715.
18. Bhatt, Pooja and Mehar, Hemant and Sahajwani, Manish, Electrical Motors for Electric Vehicle – A Comparative Study (April 3, 2019). *Proceedings of Recent Advances in Interdisciplinary Trends in Engineering & Applications (RAITEA) 2019*.
19. Jape, Swaraj & Thosar, Archana. (2017). COMPARISON OF ELECTRIC MOTORS FOR ELECTRIC VEHICLE APPLICATION. *International Journal of Research in Engineering and Technology*. 06. 12-

17. 10.15623/ijret.2017.0609004.
20. S. Derammelaere, M. Haemers, J. De Viaene, F. Verbelen and K. Stockman, "A quantitative comparison between BLDC, PMSM, brushed DC and stepping motor technologies," 2016 19th International Conference on Electrical Machines and Systems (ICEMS), Chiba, 2016, pp. 1-5.
21. Wu, Guoyuan & Boriboonsomsin, Kanok & Barth, Matthew. (2014). Development and Evaluation of an Intelligent Energy-Management Strategy for Plug-in Hybrid Electric Vehicles. Intelligent Transportation Systems, IEEE Transactions on. 15. 1091-1100. 10.1109/TITS.2013.2294342.
22. Petr Krivik and Petr Baca (January 23rd 2013). Electrochemical Energy Storage, Energy Storage - Technologies and Applications, Ahmed Faheem Zobaa, IntechOpen, DOI: 10.5772/52222. Available from:
https://www.intechopen.com/books/energy-storage-technologies-and-applications/electrochemical_energy_storage.